



The right connection
The right environment

Pressure Gauge Isolator Valve 1GI

Ref. No. H03154
Release: Jan 2019

ENGINEERING - 1 of 2

Description

Gauge Isolator valves, 1GI are meant for applications where a pressure gauge is connected to a pressure line and needs to be isolated when not in use. These can be mounted on a hydraulic manifold or a control panel.

These Isolator valves offer following advantages,

- Simple machining of the interface /panel
- Quick assembly,
- Ease of axial orientation of the Pressure gauge face for proper alignment.
- Compact and elegant assembly,
- Easy readability of the gauge.



Section

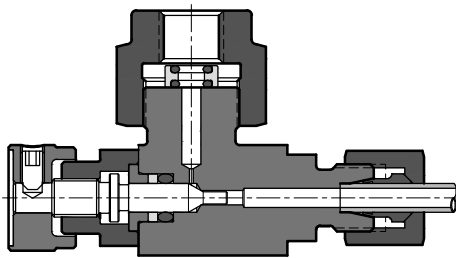

Panel Mounting, Model: 1GIP



Hydraulic Symbol

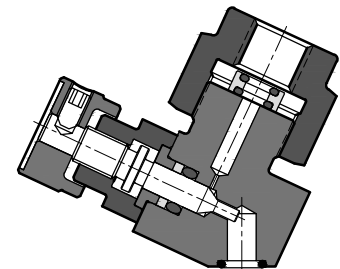

Sub-plate Mounting, Model: 1GIM

Unit Dimensions

Gauge Isolator Valve, Panel Mounting, Model: **1GIP**

Dimensions in mm.

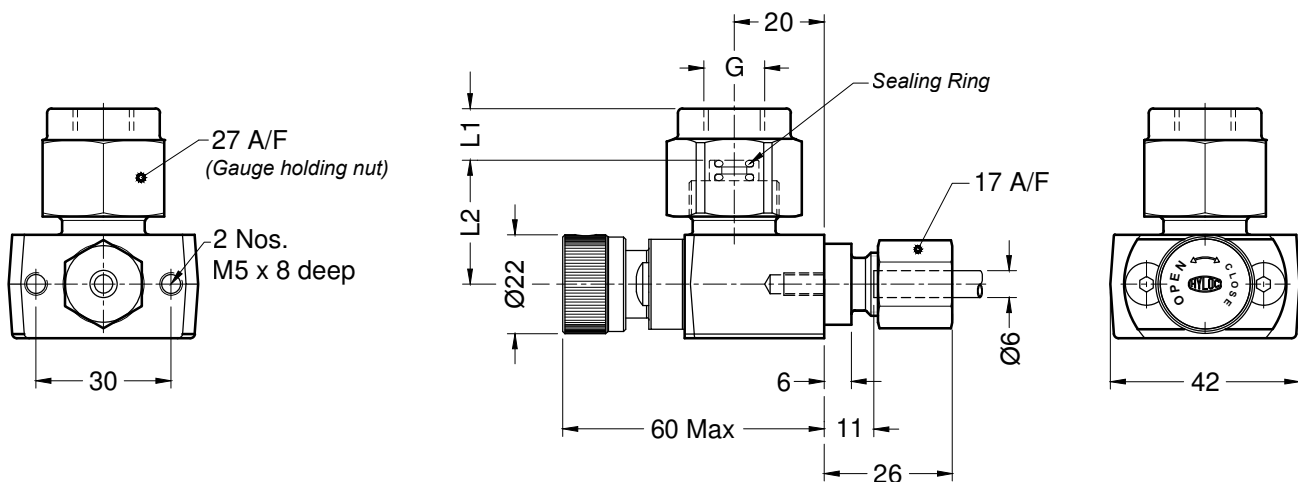

G	G 1/4	G 3/8	G 1/2
L1	11.5	11.5	12.5
L2	27.5	27.5	28.5



The right connection
The right environment

Pressure Gauge Isolator Valve 1GI

Ref. No. H03154
Release: Jan 2019

ENGINEERING - 2 of 2

Unit Dimensions

Gauge Isolator Valve, Subplate Mounting, Model: **1GIM**

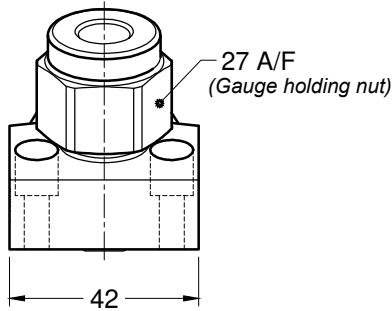

Mounting screws are not in scope of supply

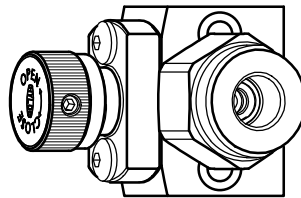
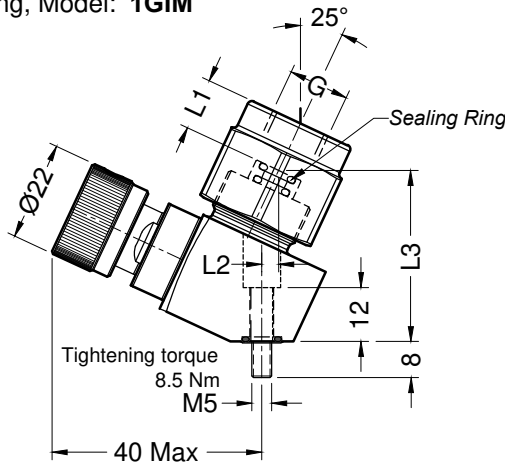

G	G 1/4	G 3/8	G 1/2
L1	11.5	11.5	12.5
L2	4.0	4.0	4.5
L3	38.5	38.5	39.5

Mounting Interface

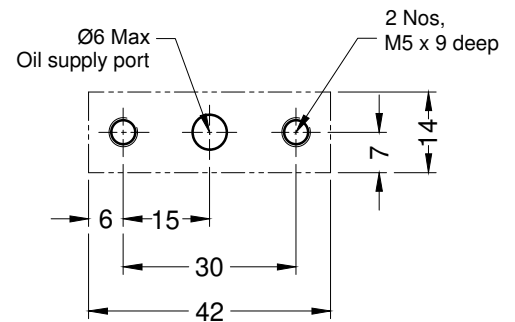

Technical Specifications

Construction	Seat type
Mounting	Sub-plate mounted or Panel mounted
Interface standard	Factory standard.
Mounting position	Optional
Operating pressure	350 bar.
Hydraulic medium	Mineral oil.
Fluid temperature range	-20 °C to +70 °C.
Fluid cleanliness requirement	As per ISO 19/16 or better

Instructions for Pressure Gauge assembly

How to orient and tighten the gauge face to the desired position?

- Screw in the *Gauge holding Nut* onto the valve till its bottom face of it touches the face of the valve body.
- Insert the sealing ring provided with the valve, from the top of the nut.
- Screw in the gauge into the *Gauge Holding Nut* till its sealing face touches the sealing ring.
- Loosen the gauge (if required) by rotating it in anti-clockwise direction till the face of the gauge points towards desired position.
- Mount the Gauge Isolating Valve on to the sub-plate or panel.
- Rotate the Gauge Holding Nut by means of a spanner in anti-clockwise direction to tighten the gauge onto the sealing ring.
- While rotating the nut, hold the gauge to its proper orientation.

Ordering Code

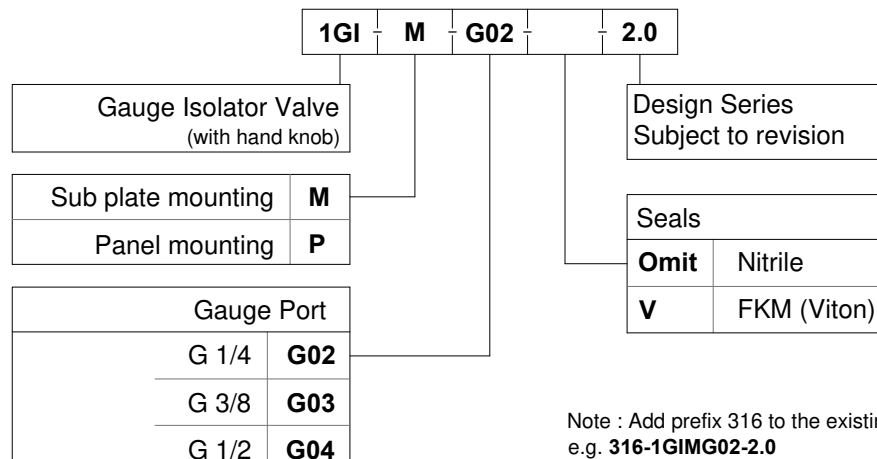

Note : Add prefix 316 to the existing part code for SS 316 valves.
e.g. **316-1GIMG02-2.0**

All rights reserved.

Subject to change without notice.

Due to continuous improvement in the design of the product, the actual product supplied may look different than shown above.